

Bespoke Solutions

In addition to our standard range, Chevin Tools' in-house designers can create special Split Boring Bar Holders to suit specific requirements.

For further information about our range of Split Boring Bar Holders, contact **Tim Thorburn** at Chevin Tools.

E: t.thorburn@chevintools.com

T: (847) 690 1278

www.chevintools.com



CVNSBBH001-ENG



**CHEVIN
TOOLS**

Split Boring Bar Holders



TOOLHOLDING

WORKHOLDING

SUB-CONTRACT MACHINING



**CHEVIN
TOOLS**

Collaborating with the World's Finest

Chevin Tools Inc

1600 Golf Road, Suite 1200, Rolling Meadows, IL 60008-4229, U.S.A

Toll Free: 1 877 4 T: (847) 690 1278 F: (847) 690 1934

E: sales@chevintools.com

www.chevintools.com

Benefits offered by Split Boring Bar Holders include:

- Compatibility with anti-vibration bars.
- Increased cutting performance.
- Deeper boring capability (up to 10 times diameter).
- Increased performance over standard boring bars.
- Available with Through-Tool Coolant.

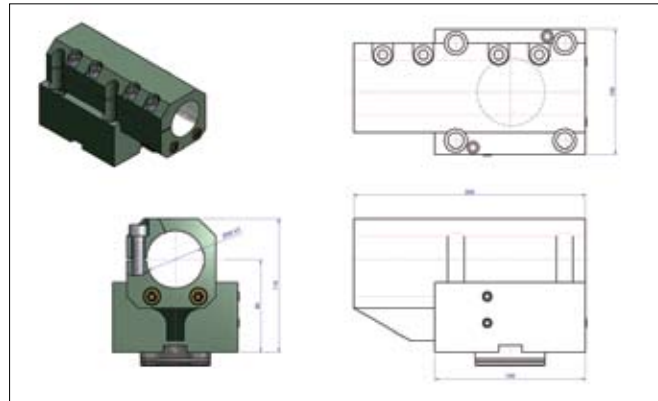
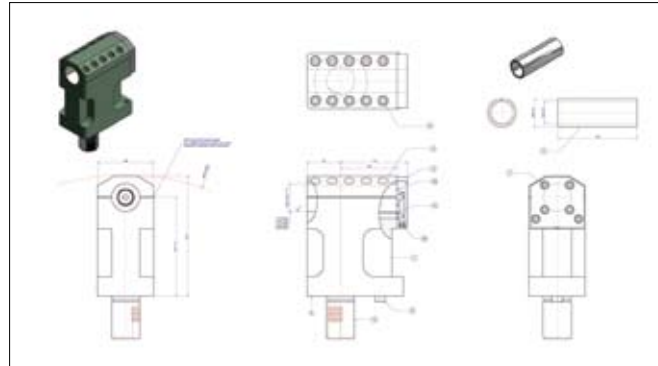

Reduction Bushes

To complement our range of Split Boring Bar Holders, we also offer **Split Reduction Bushes** for use with smaller diameter boring bars.



Wide Range of Split and Hinged Holders Available

Our extensive range of **Cap** and **Hinged-Type** Boring Bar Holders suit machines for many leading manufacturers, including **Mazak, Doosan, Okuma, Mori Seiki** and **Hwacheon**.

Cap-Type



Hinged-Type

